



7/8" (22.2 mm) Multi Turn Wirewound Potentiometer - 533: 3 Turns / 534: 10 Turns / 535: 5 Turns



FEATURES

- Bushing and servo mount designs available
- Linearity $\pm 0.25\%$, down to 0.05 % on request
- Rear shaft extensions and support bearing
- Metric shaft available
- Dual gang configuration and concentric shafts
- High torque, center tap, slipping clutch on request
- Special markings and front shaft extensions
- Material categorization: for definitions of compliance please see www.vishay.com/doc?99912



RoHS COMPLIANT

LINKS TO ADDITIONAL RESOURCES



QUICK REFERENCE DATA	
Sensor type	ROTATIONAL, multi turn wirewound
Output type	Output by turrets
Market appliance	Industrial
Dimensions	7/8" (22.2 mm)

ELECTRICAL SPECIFICATIONS			
PARAMETER	MODEL 533	MODEL 534	MODEL 535
Resistance range - standard values	50 Ω to 20 k Ω	100 Ω to 100 k Ω	50 Ω to 50 k Ω
Capability range	5 Ω to 60 k Ω	10 Ω to 200 k Ω	5 Ω to 100 k Ω
Standard tolerance	$\pm 5\%$	$\pm 5\%$	$\pm 5\%$
Linearity (independent)	$\pm 0.25\%$	$\pm 0.25\%$	$\pm 0.25\%$
Noise	100 Ω ENR	100 Ω ENR	100 Ω ENR
Rotation (electrical and mechanical)	1080° $^{+10^{\circ}}$ $^{-0^{\circ}}$	3600° $^{+10^{\circ}}$ $^{-0^{\circ}}$	1800° $^{+10^{\circ}}$ $^{-0^{\circ}}$
Power rating (at 70 °C)	1.0 W	2.0 W	1.5 W
Insulation resistance	1000 M Ω minimum 500 V _{DC}		
Dielectric strength	1000 V _{RMS} minimum 60 Hz		
Absolute minimum resistance	Not to exceed linearity x total resistance or 1 Ω , whichever is greater		
Temperature coefficient	20 ppm/°C (standard values, wire only)		
End voltage	0.25 % of total applied voltage, maximum		
Phasing	CCW end points - section 2 phased to section 1 within $\pm 2^{\circ}$		
Taps	Center tap only		

MARKING	
Unit identification	Manufacturer's name and model number, resistance value and tolerance, linearity specification date code and terminal identification. Example of a marking for a standard part: 534-11103

RESISTANCE VALUES	
533 (Ω)	50, 100, 200, 500, 1K, 2K, 5K, 10K, 20K
534 (Ω)	100, 200, 500, 1K, 2K, 5K, 10K, 20K, 50K, 100K
535 (Ω)	50, 100, 200, 500, 1K, 2K, 5K, 10K, 20K, 50K

ORDERING INFORMATION															
5	3	4	B	2	1	0	3	2	0	3	J	C	4	7	0
MODEL	STYLE	GANGS	OHMIC VALUE GANGS N° 1			OHMIC VALUE GANGS N° 2			TOLERANCE ON OHMIC VALUE	LINEARITY		SPECIAL REQUEST			
533 534 535	B: bushing S: servo	1 2	470 = 47 Ω 222 = 2.200 Ω 103 = 10 kΩ For ohmic value range see Electrical Specifications			470 = 47 Ω 222 = 2.200 Ω 103 = 10 kΩ For ohmic value range see Electrical Specifications			J = ± 5 %	C = ± 0.25 % L = ± 0.2 % On request: down to ± 0.05 %		Special code xxxx			

PART NUMBER DESCRIPTION (for information only)					
534-	1	2	103	203	xxxx
MODEL	STYLE	GANGS	OHMIC VALUE GANGS N° 1	OHMIC VALUE GANGS N° 2	SPECIAL
	B: 1 S: 2				

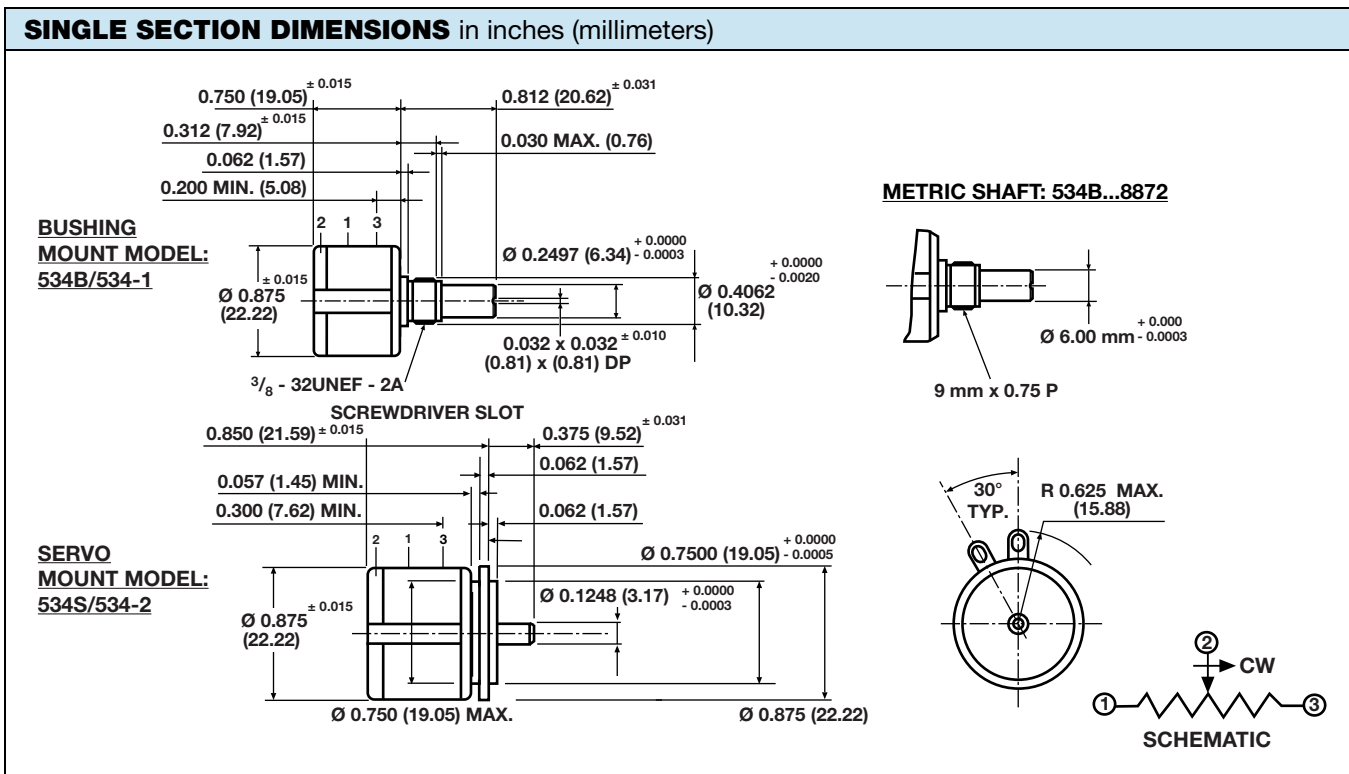

Mounting hardware, washer and panel nut, nickel plated



MECHANICAL SPECIFICATIONS		
PARAMETER		
Bearing type	Bushing: sleeve bearing	Servo: ball bearing
Torque (maximums): starting Section 1 Section 2	534 0.5 oz.-in (36 g-cm) 0.9 oz.-in (65 g-cm)	533/535 0.7 oz.-in (50 g-cm) 1.1 oz.-in (79 g-cm)
Torque (maximums): running Section 1 Section 2	534 0.4 oz.-in (28.80 g-cm) 0.7 oz.-in (50.40 g-cm)	533/535 0.6 oz.-in (43.20 g-cm) 0.9 oz.-in (64.8 g-cm)
Weight (maximums) Section 1 Section 2	0.75 oz. (21.26 g) 1.25 oz. (35.44 g)	
Stop strength	75 oz.-in (static) (5.4 kg-cm)	
Ganging	2 sections maximum	

POWER RATING CHART

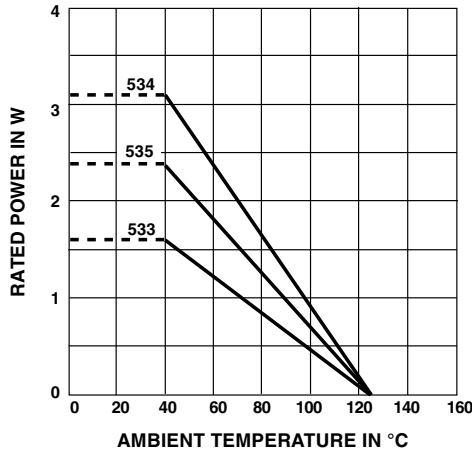

ENVIRONMENTAL SPECIFICATIONS	
Vibration	15 g thru 2000 Hz
Shock	50 g
Rotational life (shaft revolution)	
533	300 000
534	1 000 000
534 (servo)	> 1 000 000
535	500 000
Load life	900 h
Temperature range	-55 °C to +125 °C

Note

- Nothing stated herein shall be construed as a guarantee of quality or durability

RESISTANCE ELEMENT DATA														
RESISTANCE VALUE (Ω)			RESOLUTION (%)			OHMS PER TURN			MAXIMUM CURRENT AT 70 °C AMBIENT (mA)			MAXIMUM VOLTAGE ACROSS COIL (V)		
533	534	535	533	534	535	533	534	535	533	534	535	533	534	535
50	-	50	0.149	-	0.120	0.0746	-	0.0603	141.0	-	173.0	7.07	-	8.66
100	100	100	0.111	0.060	0.075	0.1114	0.0603	0.0746	100.0	141.0	122.0	10.0	14.1	12.2
200	200	200	0.097	0.037	0.061	0.1954	0.0746	0.1220	70.7	100.0	86.6	14.1	20.0	17.3
500	500	500	0.069	0.031	0.049	0.3424	0.1520	0.2459	44.7	63.2	54.7	22.4	31.6	27.4
1K	1K	1K	0.063	0.025	0.041	0.6331	0.2459	0.4113	31.6	44.7	38.7	31.6	44.7	38.7
2K	2K	2K	0.041	0.021	0.031	0.8206	0.4113	0.6331	22.4	31.6	27.4	44.7	63.2	54.8
5K	5K	5K	0.044	0.016	0.034	2.2330	0.8206	1.7230	14.1	20.0	17.3	70.7	100.0	86.6
10K	10K	10K	0.034	0.017	0.030	3.4510	1.7230	3.0160	10.0	14.1	12.2	100.0	141.0	122.0
20K	20K	20K	0.031	0.015	0.020	6.1790	3.0160	3.9910	7.07	10.0	8.66	141.0	200.0	173.0
-	50K	50K	-	0.009	0.015	-	4.6690	7.4560	-	6.32	5.47	-	316.0	274.0
-	100K	-	-	0.007	-	-	7.4560	-	-	4.47	-	-	447.0	-
-	-	-	-	-	-	-	-	-	-	-	-	-	-	-
-	-	-	-	-	-	-	-	-	-	-	-	-	-	-



Disclaimer

ALL PRODUCT, PRODUCT SPECIFICATIONS AND DATA ARE SUBJECT TO CHANGE WITHOUT NOTICE TO IMPROVE RELIABILITY, FUNCTION OR DESIGN OR OTHERWISE.

Vishay Intertechnology, Inc., its affiliates, agents, and employees, and all persons acting on its or their behalf (collectively, "Vishay"), disclaim any and all liability for any errors, inaccuracies or incompleteness contained in any datasheet or in any other disclosure relating to any product.

Vishay makes no warranty, representation or guarantee regarding the suitability of the products for any particular purpose or the continuing production of any product. To the maximum extent permitted by applicable law, Vishay disclaims (i) any and all liability arising out of the application or use of any product, (ii) any and all liability, including without limitation special, consequential or incidental damages, and (iii) any and all implied warranties, including warranties of fitness for particular purpose, non-infringement and merchantability.

Statements regarding the suitability of products for certain types of applications are based on Vishay's knowledge of typical requirements that are often placed on Vishay products in generic applications. Such statements are not binding statements about the suitability of products for a particular application. It is the customer's responsibility to validate that a particular product with the properties described in the product specification is suitable for use in a particular application. Parameters provided in datasheets and / or specifications may vary in different applications and performance may vary over time. All operating parameters, including typical parameters, must be validated for each customer application by the customer's technical experts. Product specifications do not expand or otherwise modify Vishay's terms and conditions of purchase, including but not limited to the warranty expressed therein.

Hyperlinks included in this datasheet may direct users to third-party websites. These links are provided as a convenience and for informational purposes only. Inclusion of these hyperlinks does not constitute an endorsement or an approval by Vishay of any of the products, services or opinions of the corporation, organization or individual associated with the third-party website. Vishay disclaims any and all liability and bears no responsibility for the accuracy, legality or content of the third-party website or for that of subsequent links.

Vishay products are not designed for use in life-saving or life-sustaining applications or any application in which the failure of the Vishay product could result in personal injury or death unless specifically qualified in writing by Vishay. Customers using or selling Vishay products not expressly indicated for use in such applications do so at their own risk. Please contact authorized Vishay personnel to obtain written terms and conditions regarding products designed for such applications.

No license, express or implied, by estoppel or otherwise, to any intellectual property rights is granted by this document or by any conduct of Vishay. Product names and markings noted herein may be trademarks of their respective owners.